

JULIA KROG
DIRECTOR

TELEPHONE: 707-964-5379
FAX: 707-961-2427



**COUNTY OF MENDOCINO
DEPARTMENT OF PLANNING & BUILDING SERVICES**

752 SOUTH FRANKLIN STREET
FORT BRAGG, CALIFORNIA 95437

EMERGENCY PERMIT APPLICATION FACTS TO KNOW

- The emergency permit process allows for procedures to perform work to resolve problems resulting from a situation falling within the definition of "emergency". An emergency is defined as a sudden unexpected occurrence demanding immediate action to prevent or mitigate loss or damage to life, health, property, or essential public services.
- In cases of a verified emergency, temporary emergency authorization to proceed with remedial measures may be given by the Director of Planning and Building Services (the Director) or his or her designee until such time as a coastal development permit application is filed.
- The Director may grant an emergency permit upon reasonable terms and conditions which will include, at a minimum that: the development be completed within thirty (30) days of issuance (unless otherwise specified by the terms of the permit); public comment on the proposed emergency action has been reviewed (if time allows); and the work proposed would be consistent with the requirements of the coastal program.
- An emergency permit is valid for not more than sixty (60) days from the date of issuance. **Prior to expiration of the emergency permit, the permittee must either submit a coastal development permit application for the development or remove the development undertaken pursuant to the emergency permit in its entirety and restore the site to its previous condition.**

EMERGENCY PERMIT PROJECT INTAKE CHECKLIST

The following information and materials must be submitted at the time an emergency permit application is filed with the Planning Division. **Applicants should check off each completed item in the box marked "A" and submit this checklist with the application.**

A C

1. **Two (2) copies** of items a-e on 8 ½ x 11 paper, collated and stapled into individual application packets
- a) **EMERGENCY PERMIT APPLICATION FORM** – Please be sure to answer all questions thoroughly and accurately
 - b) **EMERGENCY PERMIT QUESTIONNAIRE** – Please be sure to answer all questions thoroughly and accurately
 - c) **LOCATION MAP** – Use USGS quad maps with parcel boundaries (see attached example)
 - d) **SITE PLAN** – Drawn to scale (see attached example)
 - e) **ARCHITECTURAL/ENGINEERING PLANS & ELEVATIONS FOR THE EMERGENCY WORK** – If applicable

A C

2. **ARCHITECTURAL/ENGINEERING PLANS & ELEVATIONS FOR THE EMERGENCY WORK** - 1 Full Size Set (if applicable). Drawn to scale and folded to 8 ½ x 11 size.

A C

3. **SIGNED CERTIFICATION AND SITE VIEW AUTHORIZATION FORM** – 1 Copy.

A C

4. **SIGNED ACKNOWLEDGEMENT OF DEPOSIT** – 1 Copy.

A C

5. **SIGNED INDEMNIFICATION AGREEMENT** – 1 Copy.

A C

6. **PROOF OF APPLICANT'S LEGAL INTEREST IN THE PROPERTY** – 1 Copy. Proof can be in the form of a current tax statement, title report, lease agreement or other documents showing legal interest to apply for the permit and comply with all conditions of approval. All holders or owners of any other interest of record in the affected property shall be identified on the application and notified in writing of the permit application by the applicant and invited to join as co-applicant(s).

A C

7. **FILING FEE** – Checks to be made payable to "County of Mendocino". Please check with a planner for the fee amount.

**ADDITIONAL INFORMATION MAY BE REQUIRED AS FOLLOWS;
CONTACT THE PLANNING DIVISION FOR DETAILS.**

- **A SOILS REPORT AND SEPTIC DESIGN** will be required for emergency repair or replacement of failing septic systems. Contact the Mendocino County Department of Environmental Health for requirements.
- **A BOTANICAL SURVEY** may be required if an endangered species, Environmentally Sensitive Habitat Area (ESHA), stream, creek, wetland, pond, pygmy habitat, or sand dune occupies any portion of the site.
- **A GEOTECHNICAL REPORT** may be required if the project is on a bluff top property or within a Seismic Safety Combining District. This report must address the issues required by the Coastal Zoning Code Chapter 20.500, including but not limited to site geology, soils, soil stability, landsliding, erosion, drainage, bluff top setback, seismicity and faulting, tsunami issues, appropriateness of the proposed development on the site, and construction techniques to provide adequate stability for the development.
- **A DRAINAGE PLAN** may be required where the project has a potential to adversely affect water quality within any waterway and where the project has the potential to affect slope stability along bluffs and steep slopes.

**COUNTY OF MENDOCINO
DEPT OF PLANNING & BUILDING SERVICES
752 SOUTH FRANKLIN STREET
FORT BRAGG, CA 95437
Telephone: 707-964-5379**

Case No(s) _____
CDF No(s) _____
Date Filed _____
Fee \$ _____
Receipt No. _____
Received by _____

Office Use Only

EMERGENCY PERMIT APPLICATION FORM

Name of Applicant	Name of Owner(s)	Name of Agent
Mailing Address	Mailing Address	Mailing Address
Telephone Number	Telephone Number	Telephone Number

Project Description:

Driving Directions

The site is located on the _____ (N/S/E/W) side of _____ (name road)
approximately _____ (feet/miles) _____ (N/S/E/W) of its intersection with
_____ (provide nearest major intersection).

Assessor's Parcel Number(s)

Parcel Size	Street Address of Project
_____ D Square Feet _____ D Acres	Please note: Before submittal, please verify correct street address with the Planning Division in Ukiah.

EMERGENCY PERMIT APPLICATION QUESTIONNAIRE

The purpose of this questionnaire is to relate information concerning your application to the Planning & Building Services Department and other agencies who will be reviewing your project proposal. The more detail that is provided, the easier it will be to promptly process your application. Please answer all questions. For questions which do not pertain to your project, please indicate "Not Applicable" or "N/A".

1. NATURE OF THE EMERGENCY NARRATIVE (use additional pages if necessary).

a) Describe the nature, cause and location of the emergency.

b) Describe the remedial protective or preventive work required to deal with the emergency.

c) Describe the circumstances during the emergency that justify the course(s) of action taken, including the probable consequences of failing to take action.

d) Describe any secondary improvements such as wells, septic systems, grading, vegetation removal, roads, etc. that are necessary to deal with the emergency.

2. Are there existing structures on the property? Yes No

If yes, describe below and identify the use of each structure on the plot plan.

3. Is any grading or road construction planned? Yes No

Estimate the amount of grading in cubic yards _____ c.y. If greater than 50 cubic yards or if greater than 2 feet of cut or 1 foot of fill will result, please provide a grading plan.

Describe the terrain to be traversed (e.g., steep, moderate slope, flat, etc.).

4. Will vegetation be removed on areas other than the building sites and roads? Yes No
If yes, explain:

5. Project Height. Maximum height of structure(s): _____ feet

6. Describe all exterior materials and colors of all proposed structures that are visible beyond the boundaries of the subject parcel.

7. Are there any water courses, anadromous fish streams, ponds, lakes, sand dunes, rookeries, marine mammal haul-out areas, wetlands, riparian areas, pygmy vegetation, rare or endangered plants, animals or habitat which support rare and endangered species located on the project site or within 100 feet of the project site?

CERTIFICATION AND SITE VIEW AUTHORIZATION

- 1. I hereby certify that I have read this completed application and that, to the best of my knowledge, the information in this application, and all attached appendices and exhibits, is complete and correct. I understand that the failure to provide any requested information or any misstatements submitted in support of the application shall be grounds for either refusing to accept this application, for denying the permit, for suspending or revoking a permit issued on the basis of such misrepresentations, or for seeking of such further relief as may seem proper to the County.

- 2. I hereby grant permission for County Planning and Building Services staff and hearing bodies to enter upon and site view the premises for which this application is made in order to obtain information necessary for the preparation of required reports and render its decision.

_____ Date

Owner/Authorized Agent

NOTE: IF SIGNED BY AGENT, OWNER MUST SIGN BELOW.

AUTHORIZATION OF AGENT

I hereby authorize _____ to act as my representative and to bind me in all matters concerning this application.

_____ Date

Owner

MAIL DIRECTION

To facilitate proper handling of this application, please indicate the names and mailing addresses of individuals to whom you wish correspondence and/or staff reports mailed if different from those identified on Page One of the application form.

Name	Name	Name
Mailing Address	Mailing Address	Mailing Address



COUNTY OF MENDOCINO
DEPARTMENT OF PLANNING AND BUILDING SERVICES
860 NORTH BUSH STREET • UKIAH • CALIFORNIA • 95482
752 SOUTH FRANKLIN STREET • FORT BRAGG • CALIFORNIA • 95437

JULIA KROG, DIRECTOR
TELEPHONE: 707-234-6650
FAX: 707-463-5709
FB PHONE: 707-964-5379
FB FAX: 707-961-2427
pbs@mendocinocounty.gov
www.mendocinocounty.gov/pbs

ACKNOWLEDGEMENT OF DEPOSIT/HOURLY FEE

By signing below, the applicant acknowledges that the staff at Planning and Building Services has discussed the potential for collection of a deposit fee for the projects listed below (as adopted by the Board of Supervisors Resolution No. 23-190)

1. Division of Land Project
2. General Plan Project
3. Coastal Project
4. Zoning Project
5. Administrative Project
6. Cannabis Project
7. Private Road Naming

Once an application has been submitted and the processing costs approach 80% of the initial qualifying fee paid, a deposit equal to 50% of the base fee will be required for further processing. It is possible that during project review, additional deposits may be required depending on the complexity of the project and the staff time necessary to complete application processing.

I acknowledge that I was advised of the deposit fee for continued processing after the initial application fee has been expended.

Applicant Signature

Date

OFFICE USE ONLY:

Project or Permit Number



COUNTY OF MENDOCINO

DEPARTMENT OF PLANNING AND BUILDING SERVICES

860 NORTH BUSH STREET • UKIAH • CALIFORNIA • 95482

752 SOUTH FRANKLIN ST • FORT BRAGG • CALIFORNIA • 95437

JULIA KROG, DIRECTOR

PHONE: 707-234-6650

FAX: 707-463-5709

FB PHONE: 707-964-5379

FB FAX: 707-961-2427

pbs@mendocinocounty.gov

www.mendocinocounty.gov/pbs

Indemnification And Hold Harmless

ORDINANCE NO. 3780, adopted by the Board of Supervisors on June 4, 1991, requires applicants for discretionary land use approvals, to sign the following Indemnification Agreement. Failure to sign this agreement will result in the application being considered incomplete and withheld from further processing.

Indemnification Agreement

As part of this application, applicant agrees to defend, indemnify, release and hold harmless the County of Mendocino, its agents, officers, attorneys, employees, boards and commissions, as more particularly set forth in Mendocino County Code Section 1.04.120, from any claim, action or proceeding brought against any of the foregoing individuals or entities, the purpose of which is to attack, set aside, void or annul the approval of this application or adoption of the environmental document which accompanies it. The indemnification shall include, but not be limited to, damages, costs, expenses, attorney fees or expert witness fees that may be asserted by any person or entity, including the applicant, arising out of or in connection with the approval of this application, whether or not there is concurrent, passive or active negligence on the part of the County, its agents, officers, attorneys, employees, boards and commissions.

Date

Applicant

Sample Plot Plan

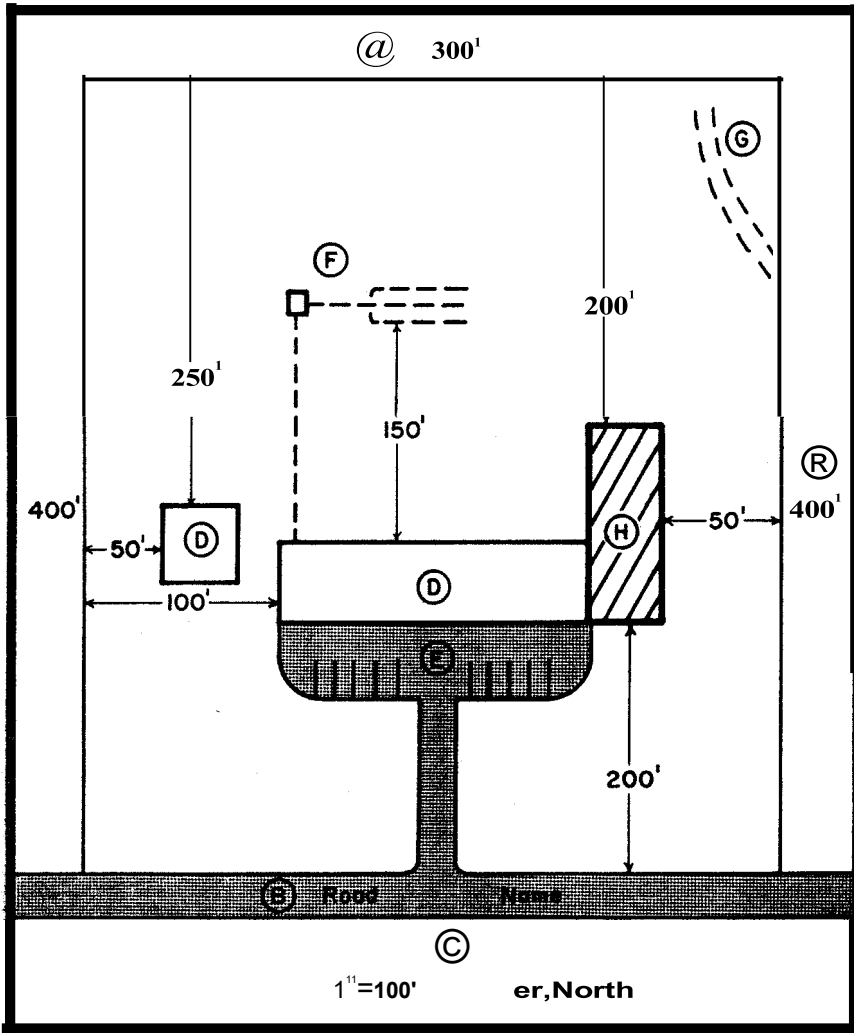

- A. Parcel Shape and Dimensions.
- B. Adjacent Streets.
- C. North Arrow and Scale.
- D. Existing Buildings including distance from property lines.
- E. Driveways, Parking and Loading Areas.
- F. Existing and proposed septic system and wells including distances from structures.
- G. Easements and Utility lines (power, sewer, water etc.).
- H. Proposed structure or addition including distance from property lines.

Sample Location Map

